

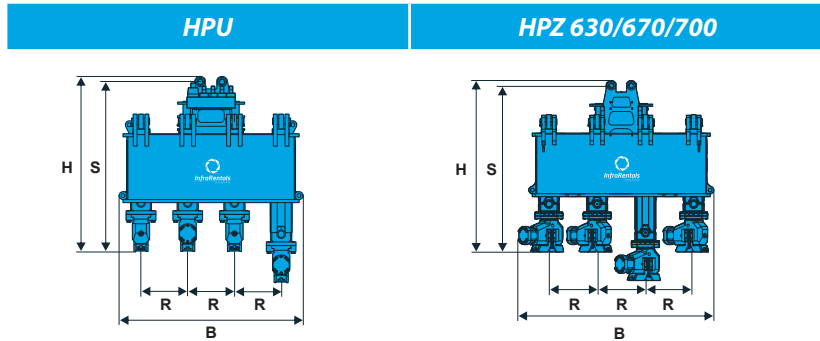

# Hydro-Press-System

Mäklergeführtes hydraulisches System zum statischen Pressen von Spundprofilen

## Technische Daten



	HPU	HPZ 630/670/700
Einpresskraft (kN)	4 x 800	4 x 800
Ziehkraft (kN)	4 x 600	4 x 600
Press- / Zieh-Hub (mm)	4 x 400	4 x 400
Hydraul. Volumenstrom max. (l/min)	420	420
Arbeitsdruck (MPa)	32	32
Gesamtgewicht / Transportgewicht (kg)	6140 / 6620	6470 / 7250

### Geeignete Spundwandprofile

	U-Profile	Z-Profile
ESI / IRZ / Arcelor Kaltgeformte Profile	PU6, PU8, PU12, PU16, PU20	IRZ18, IRZ26, IRZ36, IRZ36-700, IRZ38-700, IRZ40-700
Vitkovice (VL)	VL601, VL602, VL603, VL604, VL605	-
H (mm)	2250	2400
S (mm)	2180	2330
B (mm)	2360	2950
T (mm)	1030	980
R (mm)	600	630/670/700 <sup>1</sup>

### Transportmaße

h (mm)	2535	2630
b (mm)	2360	2950
t (mm)	1240	1100

<sup>1</sup> Mechanisch verstellbar, andere Teilungen auf Anfrage

