

Auger Drives

Excavator mounted add-on auger drives without concrete passage BA

Excavator mounted add-on auger drives with concrete passage and optional with concrete swivel DBA and casing twister RDV.

Technical data¹

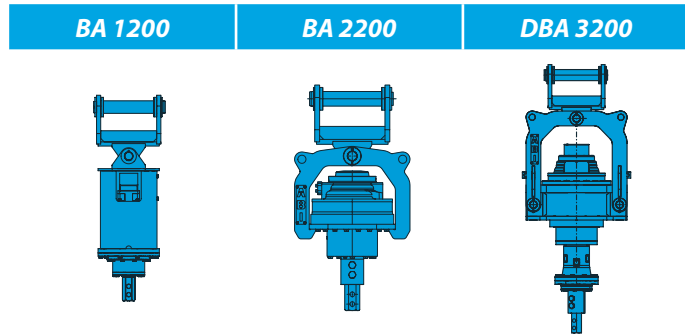

	BA 1200	BA 2200	DBA 3200
Torque (daNm)	1200	2200	3200
Revolutions/Revolutions max. (min-,)	73	50	50
Static extraction force max. (kN)	120	200	200
Hydraulic flow rate (l/min)	220	220	300
Required oil quantity per rotation (l)	3,0	4,4	6,3
Max. hydr. power at auger drive (kW)	90	60	160
Nominal oil pressure (MPa)	30	32	32
Concrete passage Inner diameter (mm)	-	-	90
Hexagon connection standard (SW - Z Socket/male) (mm)	80	80	80
Total weight / transport weight (kg)	430	600 / 700	1050 / 1360
Concrete swivel (option)	-	-	NW 100/4,5"
Hexagon connection for concreting (SW - Z Socket/male) (mm)	-	-	120 (150)
Total weight / transport weight with concrete swivel (kg)	-	-	1350 / 1660

¹ cardanic suspension required

